

# KELCO

## C25 INLINE FLOW SWITCH

High performance 25mm inline flow switches with advanced features make the C25 an ideal choice for many system designers.

### FEATURES

- One piece brass body
- All position mounting
- Diesel and oil models available
- Choice of two electrical modules
- Choice of three switching ranges
- Very low dead loss
- Fully serviceable
- Weatherproof

The C25 inline flow switches are versatile magnetically actuated normally off flow switches that switch on in response to a selectable flow. They are ideal for a multitude of clean liquid applications including pressure boosting and for the direct control of pumps or fans. The C25 flow switches can be supplied with reed switch contacts for relay or PLC control or with a built in 40 Amp solid state switch for the direct control of single phase motors up to 3kW 4HP.



### APPLICATIONS

The C25 flow switches can be used in many clean liquids, including fresh water, sea water, and diesel fuel.

### INSTALLATION

The C25 flow switches can be positioned in any orientation in pipework. In vertical piping, flow can be either upward or downward through the switch with very little difference in flow sensitivity. The C25 flow switch is suitable for use with hot or cold liquids up to 90°C. Systems can be steam sterilized at 100°C for short periods without damaging the switch.

### SWITCH POINT DATA

Switching point and sensitivity to flow depends on liquid velocity, viscosity and piston clearance. To give users as wide a choice as possible, three pistons and a non-magnetic piston retainer are supplied with the C25 flow switches. The three pistons allow the choice of a high, low or intermediate range of switching thresholds.

### CONSTRUCTION

The C25 flow switch consists of a sealed electrical switching module that saddles a one-piece metal body. The self contained electrical modules fitted to the flow switches is easily removed without disturbing pipework, and can be reversed or rotated independently of the switch body. Within the metal body of the flow switch a free fitting magnetically suspended piston actuates the switch as soon as flow starts.

### HAZARDOUS APPLICATIONS

The C25-B flow switch with an in built dry contact reed switch can be used in hazardous areas. The switches are classed as simple devices as they do not contain components capable of storing or producing an electric charge. As simple devices the switches can be used in hazardous applications provided they are isolated by an intrinsically safe barrier, a Zener barrier. The model C25-R flow switch is not suited to such applications, and will only operate in AC circuits.

Switching points when using the fitted magnetic piston repelling / retaining assembly

Piston Markings	Switching Point on a Slowly Rising Flow in Litres per Minute	Switching Point on a Slowly Reducing Flow in Litres Per Minute	Electrical Response Time in Seconds
A (Fitted)	1	0.6	0.1
B	4	3.2	0.1
C	8	5.5	0.1

Switching points when using the supplied non-magnetic retainer (to be used in vertically mounted applications only)

Piston Markings	Switching Point on a Slowly Rising Flow in Litres per Hour	Switching Point on a Slowly Reducing Flow in Litres Per Hour	Electrical Response Time in Seconds
A	30	30	0.1
B	40	40	0.1
C	50	50	0.1

Note: The data shown in the tables above refers to water at ambient temperature as the test medium. Increasing fluid viscosity will decrease the flow rate required to actuate the switch. Decreasing the fluid viscosity will proportionally increase the switch on flow rate.

## GENERAL LAYOUT

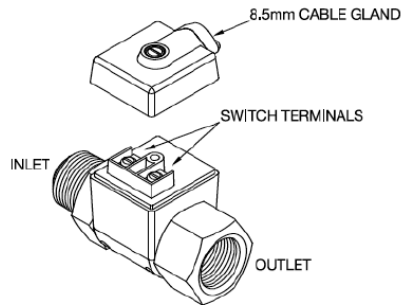

## DIMENSIONS

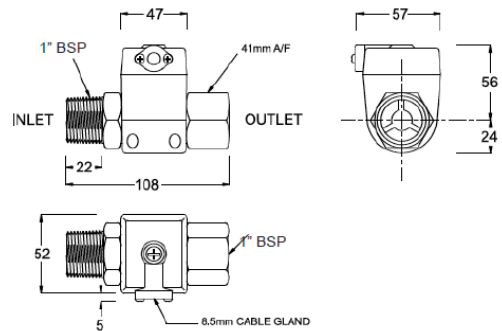

## ELECTRICAL APPLICATIONS

All C25 flow switches are single pole single throw normally open switches that switch on in response to flow. The model C25-B is suitable for PLC use, data logging, telemetry systems, relay logic circuits, or any light duty control application in either AC or DC circuits. It is rated at 0 to 240V AC at 40Watts maximum switched power. The model C25-R is suitable for AC use only, and can directly control any AC motor load up to 3kW 4HP. The C25-R will not operate in DC circuits or in circuits that draw less than 10mA.

## ENVIRONMENT

Maximum Liquid Temperature	90°C, 100°C for short periods
Minimum Liquid Temperature	-20°C
Max. Liquid Pressure	100 Bars (1450 PSI)
Ingress Protection Rating	IP56

## ELECTRICAL DATA

Electrical Module	Module Type	Contact Configuration	Switched Power Maximum	Switched Voltage Maximum	Switched Current Resistive AC (rms)	Inductive Loads (Power Factor 4.0)	Typical Application
B	Dry contact reed switch	S.P.S.T Normally Open	40Watts	240V AC 200V DC	1 Amp Maximum	Not Suitable	PLC Telemetry and relay logic circuits
R	Solid state switch	S.P.S.T Normally Open	3kW 4HP	5 to 240V AC	10mA Minimum 40 Amps Maximum	40 Amps at 240V	AC control circuits and motor control

## AVAILABLE MODELS

MODEL	DESCRIPTION
C25-B	Dry Reed Switch. S.P.S.T NO. 40 Watt. 240VAC, 200VDC. 1 Amp Max. Suitable for PLC, Telemetry and Logic circuits.
C25-B-D	Diesel Compatible Dry Reed Switch. S.P.S.T NO. 40 Watt. 240VAC, 200VDC. 1 Amp Max. Suitable for PLC, Telemetry and Logic circuits.
C25-R	Solid State Relay. S.P.S.T Normally Open. 3kW. 5 to 250VAC. 10mA Min, 40 Amps Max. Suitable for inductive loads.

Please note: Subject to 120 piece minimum order quantities, Stainless body and NPT thread versions of the above models are available.

## HEAD LOSS VERSUS FLOW RATE

Table based on test results from water only.

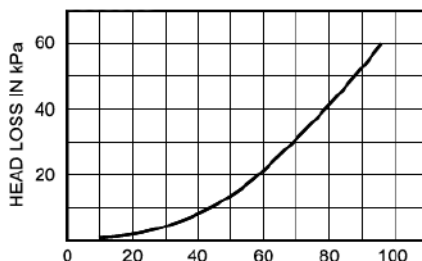

AUSTRALIAN MADE