

Date	0	Issued for customer approval

**STANDARD TOLERANCES:**  
 0 - 1000 ± 3  
 1000 - 4050 ± 5

**ALL DIMENSIONS IN mm UNLESS OTHERWISE SPECIFIED**

--	--

Customer		ECE Quote/Job No.	
Customer approval		ECE Dwg No.	
Drawn by	Date	Revision	Units: mm
			Scale: NTS

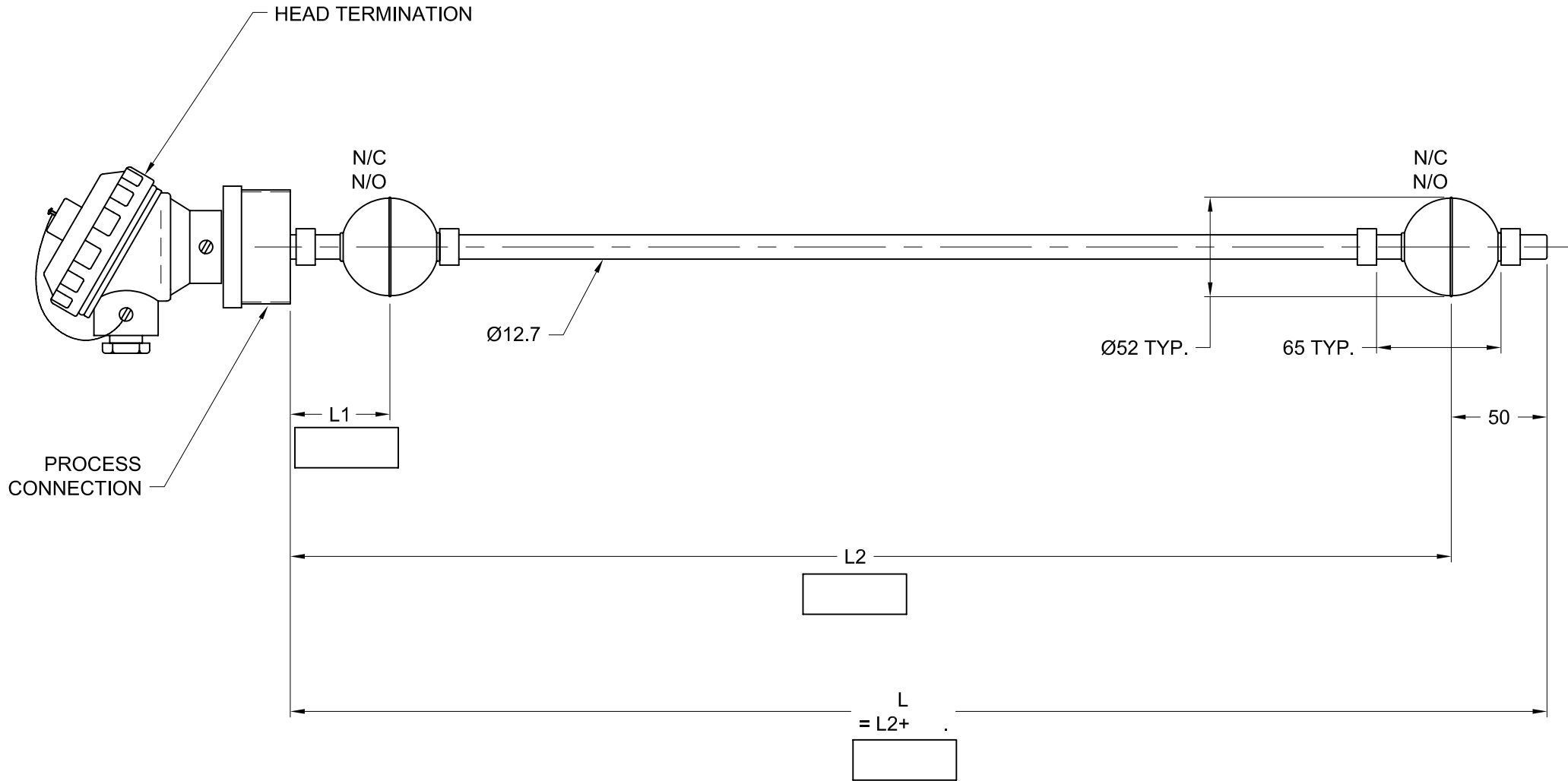

Date	0	Issued for customer approval

**STANDARD TOLERANCES:**  
 0 - 1000 ± 3  
 1000 - 4050 ± 5  
**ALL DIMENSIONS IN mm UNLESS OTHERWISE SPECIFIED**

Customer		ECE Quote/Job No.	
Customer approval		ECE Dwg No.	
Drawn by	Date	Revision	Units: mm
			Scale: NTS

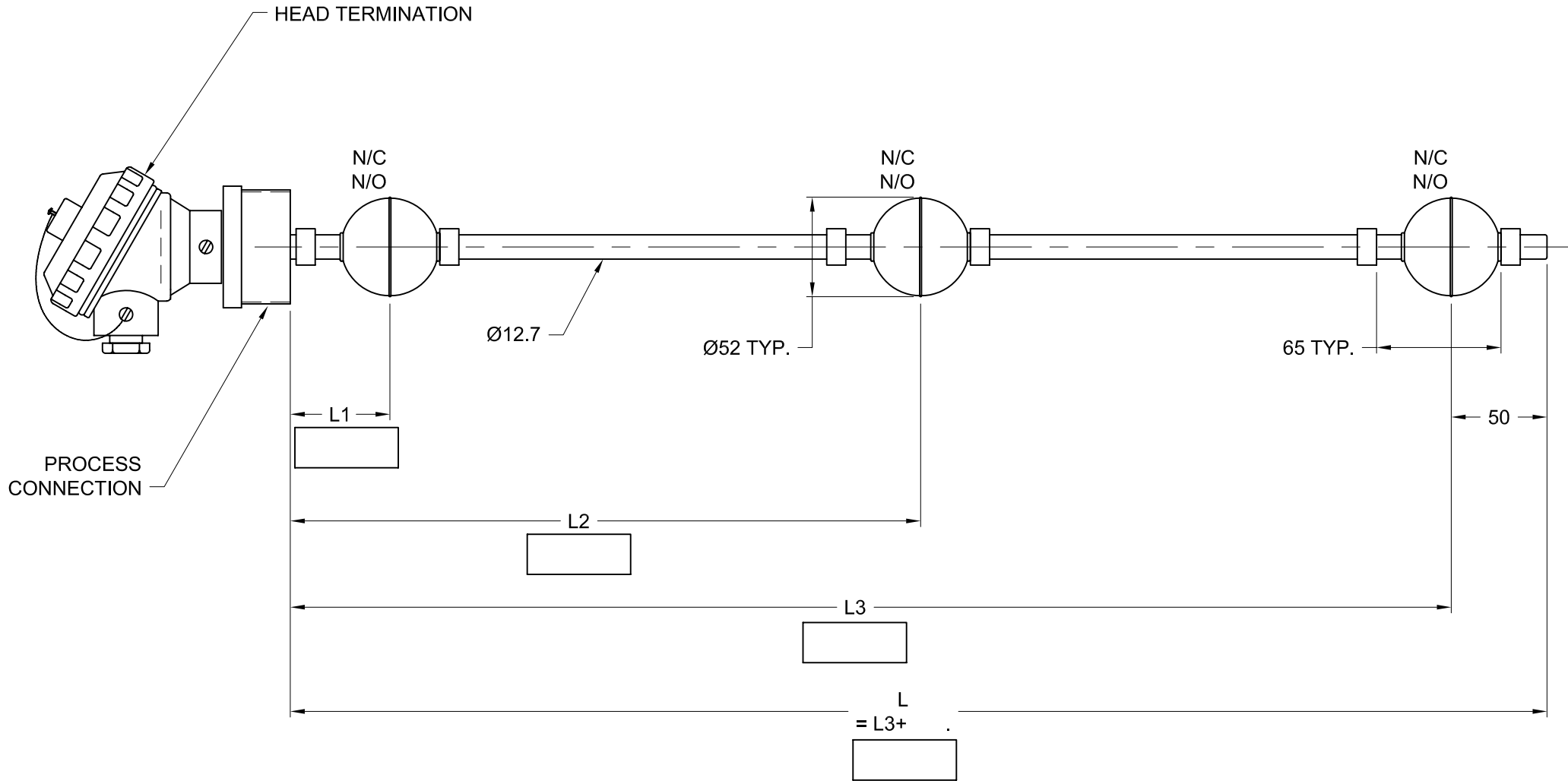

Date	0	Issued for customer approval

**STANDARD TOLERANCES:**  
 0 - 1000 ± 3  
 1000 - 4050 ± 5  
**ALL DIMENSIONS IN mm UNLESS OTHERWISE SPECIFIED**

Customer		ECE Dwg No.	
Customer approval		ECE Dwg No.	
Drawn by	Date	Revision	Units: mm
			Scale: NTS

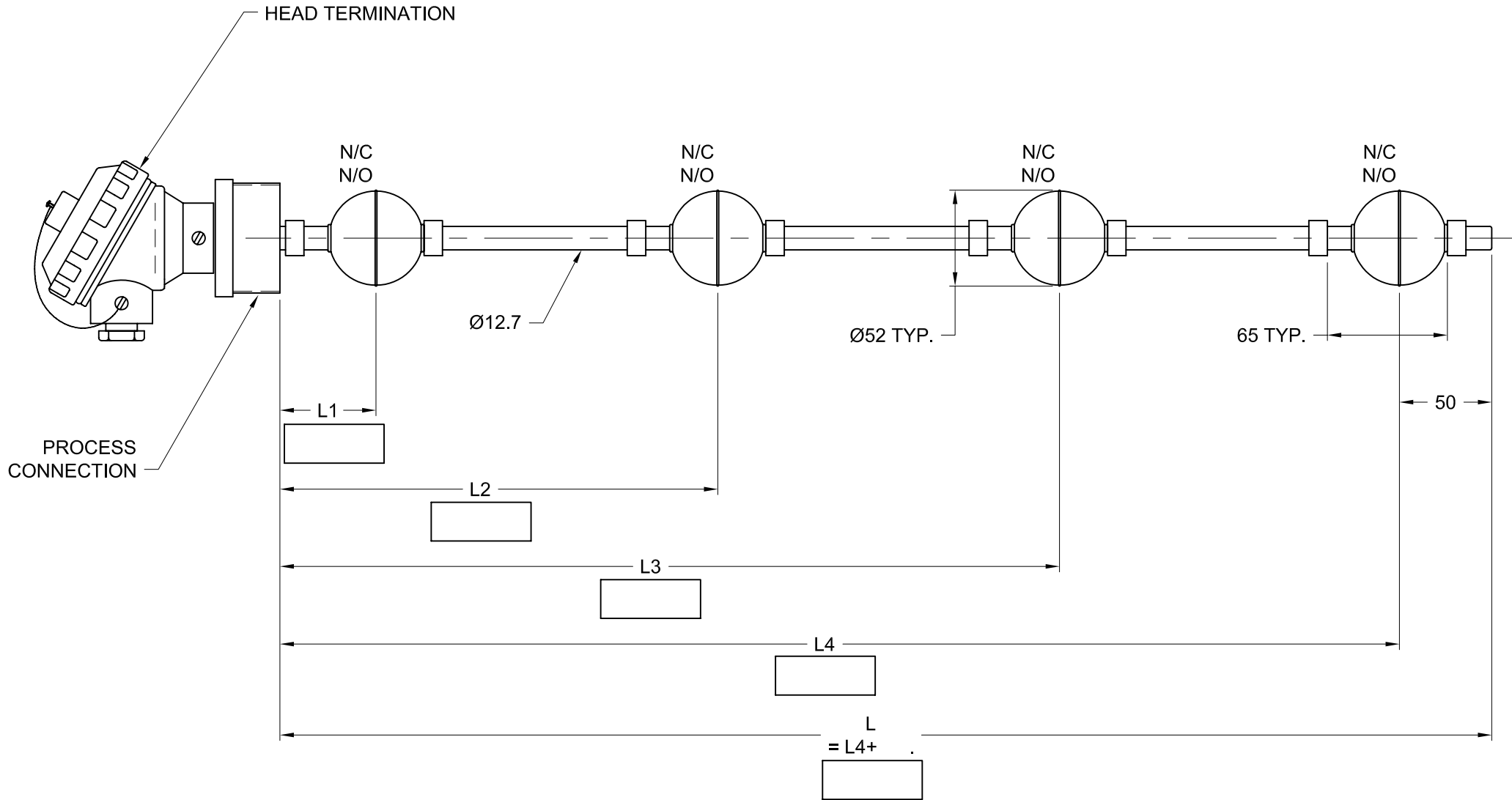

Date	0	Issued for customer approval

**STANDARD TOLERANCES:**  
 0 - 1000 ± 3  
 1000 - 4050 ± 5  
**ALL DIMENSIONS IN mm UNLESS OTHERWISE SPECIFIED**

Customer		ECE Quote/Job No.	
Customer approval		ECE Dwg No.	
Drawn by	Date	Revision	Units: mm
			Scale: NTS

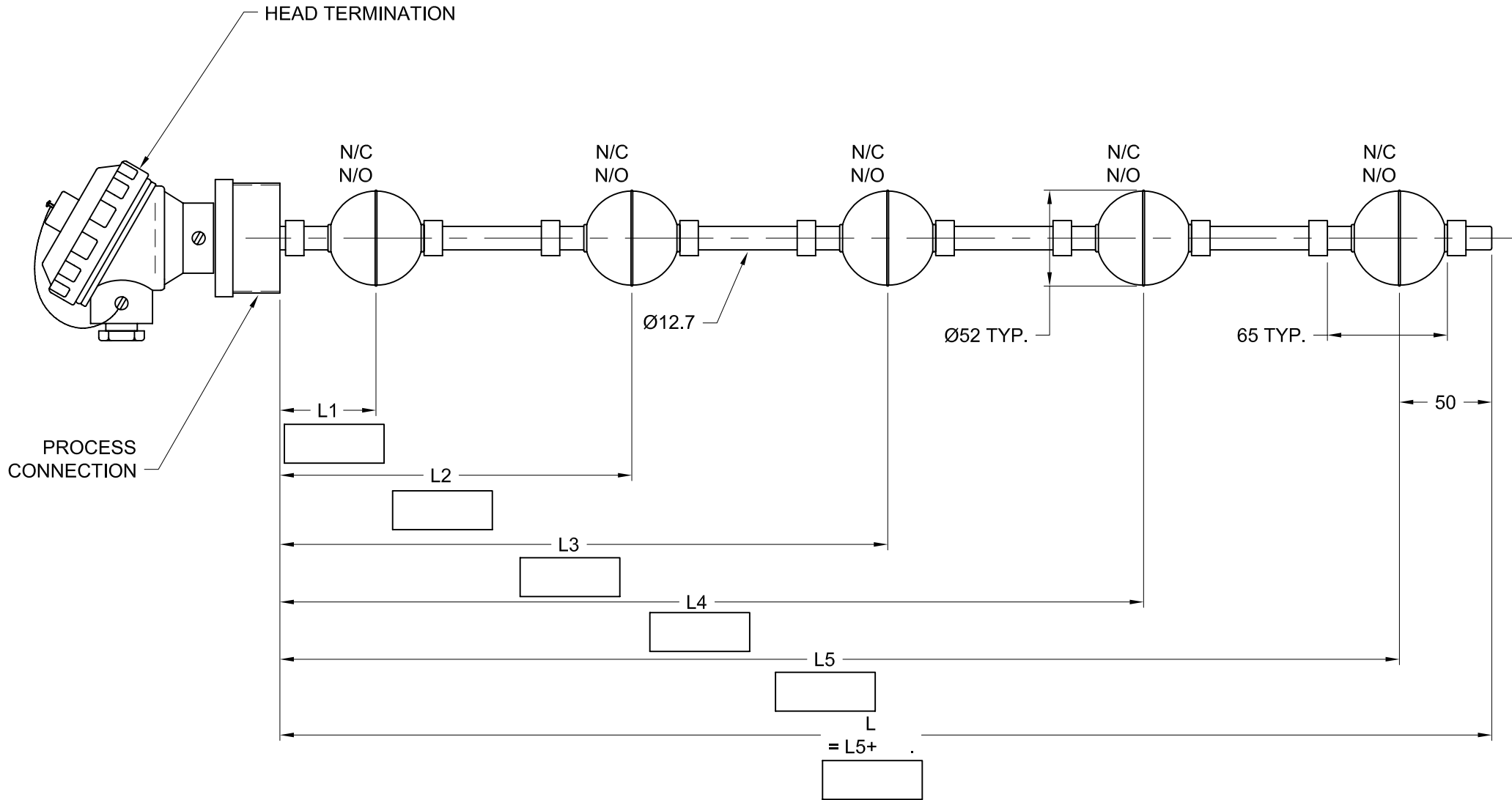

Date	0	Issued for customer approval

**STANDARD TOLERANCES:**  
 0 - 1000 ± 3  
 1000 - 4050 ± 5  
**ALL DIMENSIONS IN mm UNLESS OTHERWISE SPECIFIED**

Customer		ECE Quote/Job No.	
Customer approval		ECE Dwg No.	
Drawn by	Date	Revision	Units: mm
			Scale: NTS

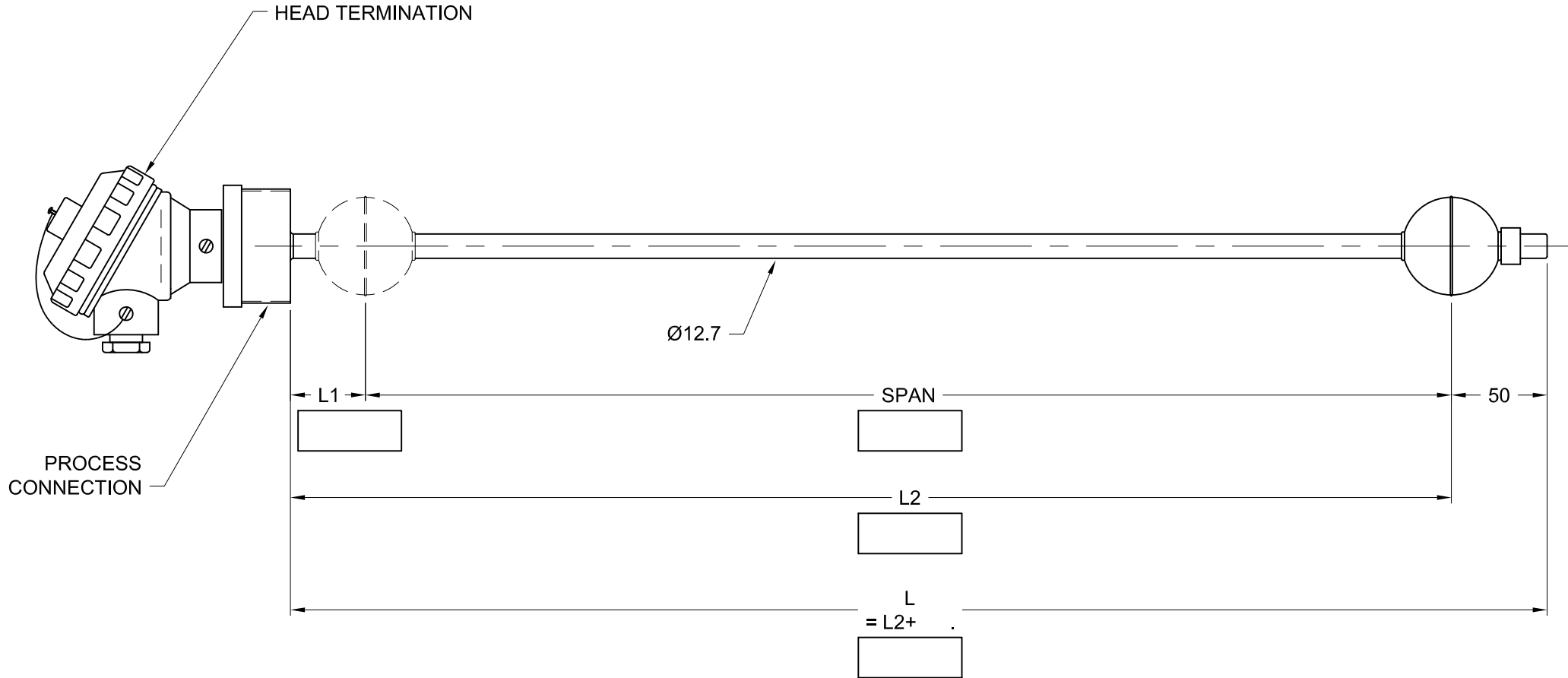

Date	0	Issued for customer approval

**STANDARD TOLERANCES:**  
 0 - 1000 ± 3  
 1000 - 4050 ± 5

**ALL DIMENSIONS IN mm UNLESS OTHERWISE SPECIFIED**

Customer

Customer approval

Drawn by

ECE Quote/Job No.

ECE Dwg No.

Date

Revision

Units: mm  
 Scale: NTS