

Date	0	Issued for customer approval

STANDARD TOLERANCES:
 0 - 1000 ± 3
 1000 - 4050 ± 5

ALL DIMENSIONS IN mm UNLESS OTHERWISE SPECIFIED

Customer		ECE Quote/Job No.	
Customer approval		ECE Dwg No.	
Drawn by	Date	Revision	Units: UNITS
			Scale: NTS

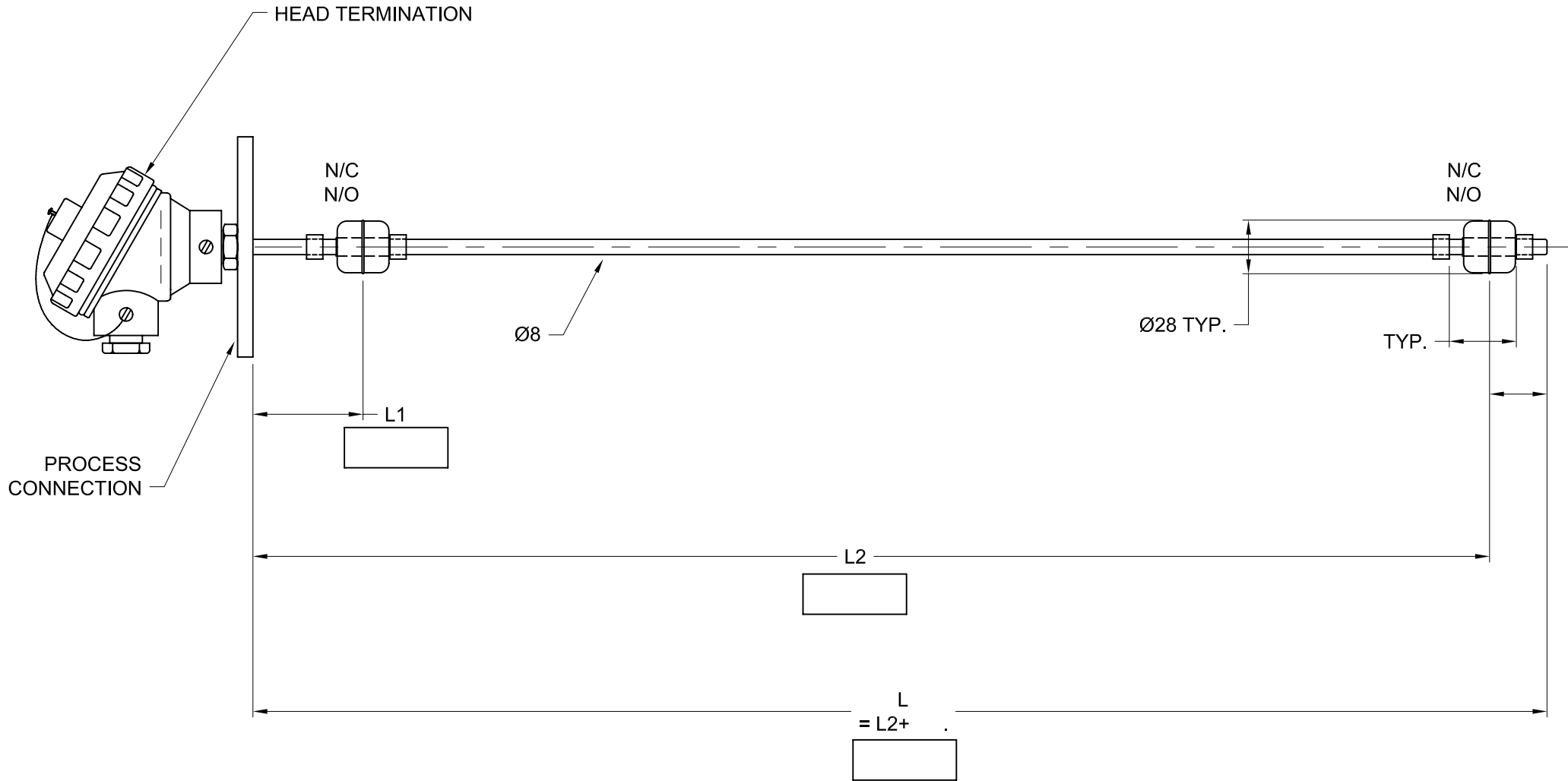

Date	0	Issued for customer approval

STANDARD TOLERANCES:
 0 - 1000 ± 3
 1000 - 4050 ± 5

ALL DIMENSIONS IN mm UNLESS OTHERWISE SPECIFIED

Customer		ECE Quote/Job No.	
Customer approval		ECE Dwg No.	
Drawn by	Date	Revision	Units: UNITS
			Scale: NTS

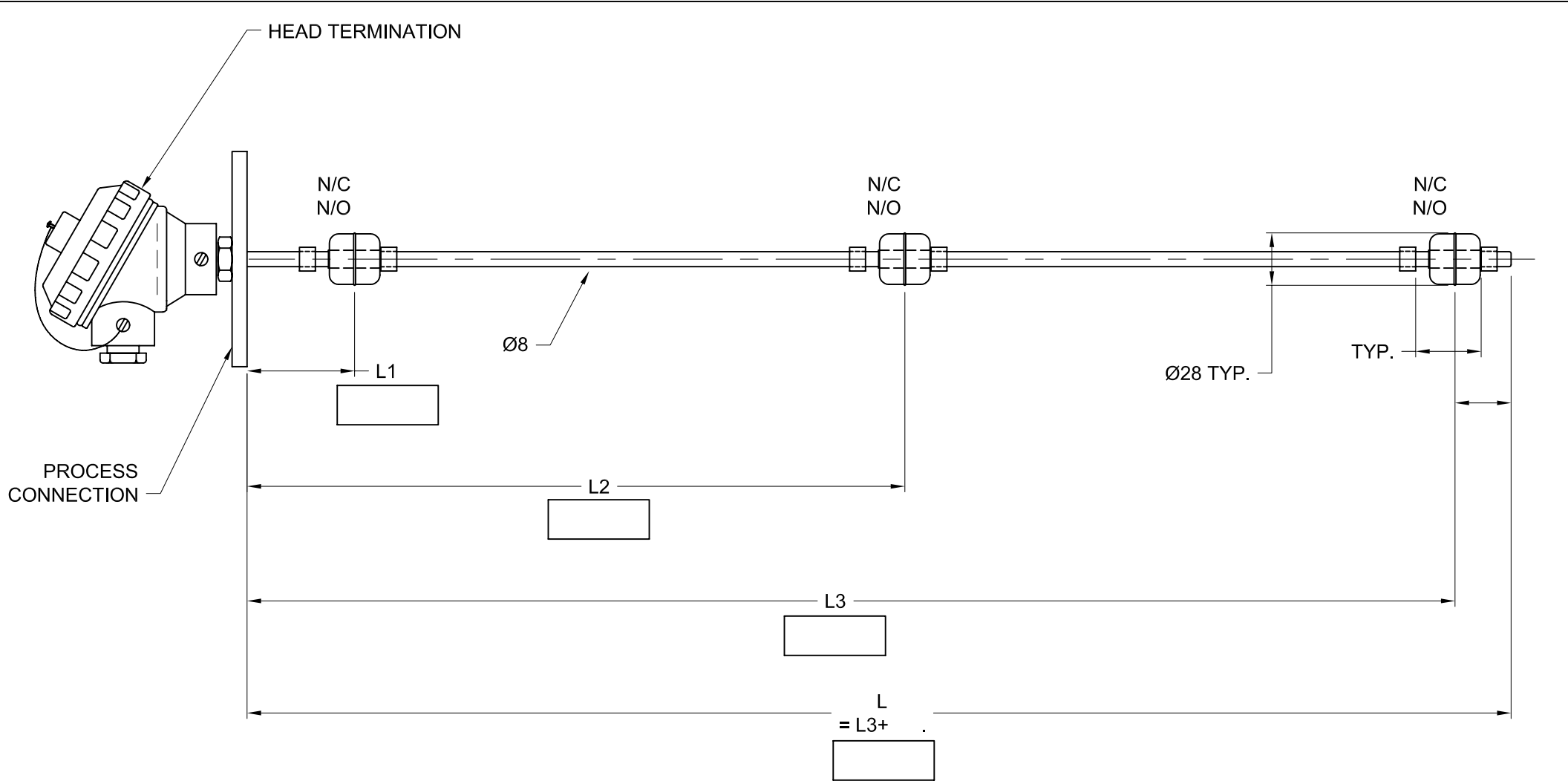

Date	0	Issued for customer approval

STANDARD TOLERANCES:
 0 - 1000 ± 3
 1000 - 4050 ± 5

ALL DIMENSIONS IN mm UNLESS OTHERWISE SPECIFIED

Customer		ECE Quote/Job No.	
Customer approval		ECE Dwg No.	
Drawn by	Date	Revision	Units: mm
			Scale: NTS

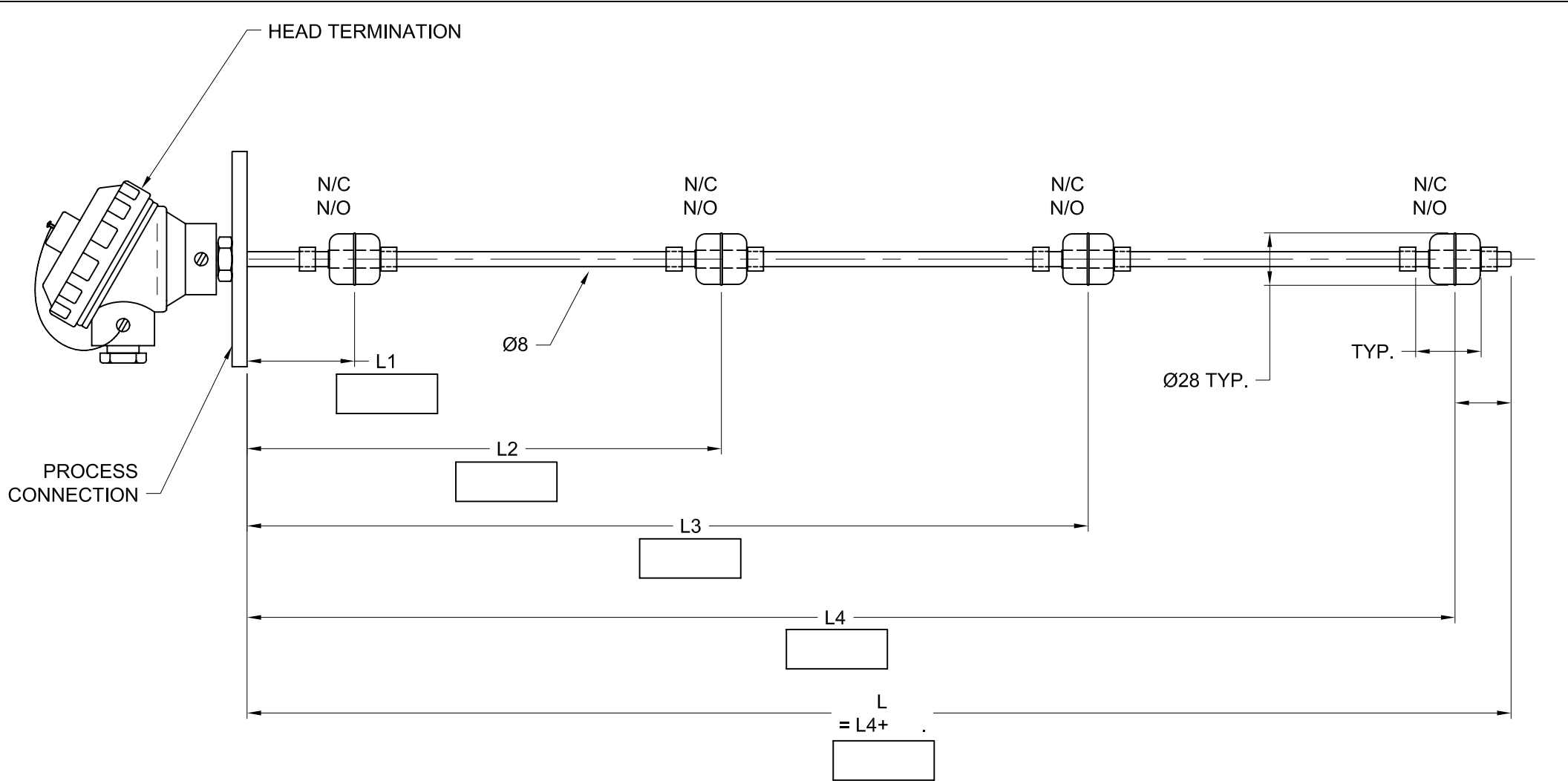

Date	0	Issued for customer approval

STANDARD TOLERANCES:
 0 - 1000 ± 3
 1000 - 4050 ± 5
ALL DIMENSIONS IN mm UNLESS OTHERWISE SPECIFIED

Customer		ECE Quote/Job No.	
Customer approval		ECE Dwg No.	
Drawn by	Date	Revision	Units: mm
			Scale: NTS

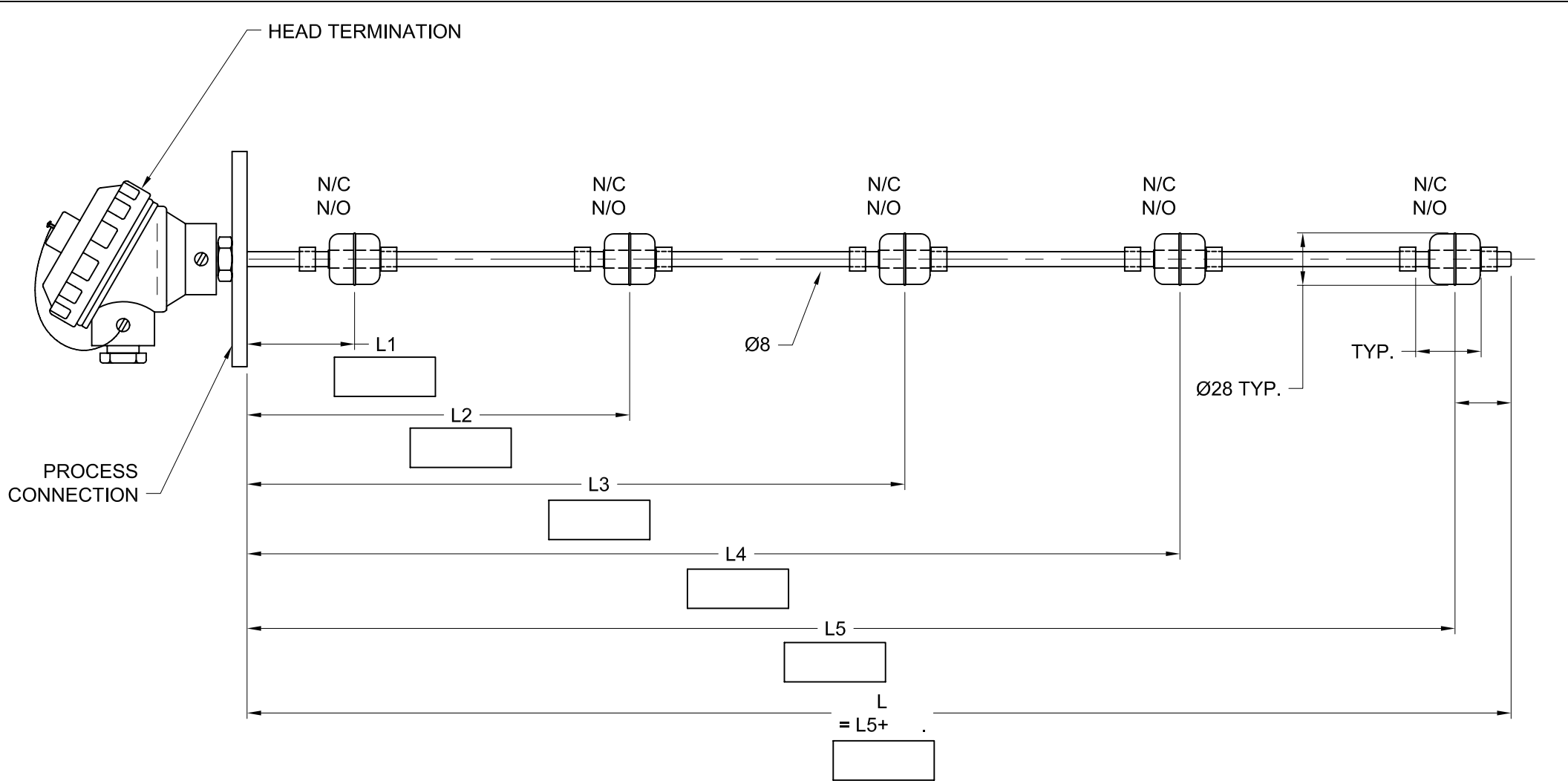

Date	0	Issued for customer approval

STANDARD TOLERANCES:
 0 - 1000 ± 3
 1000 - 4050 ± 5
ALL DIMENSIONS IN mm UNLESS OTHERWISE SPECIFIED

Customer		ECE Quote/Job No.	
Customer approval		ECE Dwg No.	
Drawn by	Date	Revision	Units: mm
			Scale: NTS